

Lighting the Way to Surgery: What is Needed in a Surgical Light



This Continuing Education
Study Guide Presented by



Authors of this educational material are clinical education employees of STERIS Corporation and do not receive additional compensation for this activity.

STERIS Corporation is providing this educational content. Specific products pictured are used to support this material and do not constitute commercial support.

Lighting the Way to Surgery: What is Needed in a Surgical Light - Study Guide #03

To receive 1.0 contact hour for completing this study guide, you must:

1. Read the complete study guide.
2. Complete the review questions and compare your responses with the answers provided. If some areas are unclear, review that section of the study guide that is indicated in parentheses next to the correct answer on the answer sheet.
3. Next:
 - > Complete the Evaluation Form. – Signature required
 - > Send the completed Evaluation Form to:

STERIS Corporation
Clinical Education Department
5960 Heisley Road
Mentor, OH 44060-1834
Phone: 800-548-4873
Fax: 440-392-8902
E-mail: clinicaleducation@steris.com

4. A Certificate of completion will be sent to you.

Accreditation/Contact Hours

Study Guide 3 for 1.0 contact hour is provided by STERIS Corporation, which is an approved provider of continuing nursing education by the California Board of Registered Nursing – provider number CEP11681.

Description of Study Guide Topic

Appropriate lighting is a critical element for a successful surgery. Whether lighting is provided during a major procedure in an operating room or for minor surgery in a physician's office, lighting must allow adequate visibility of the surgical site. Illumination of body cavities and structures, adequate light intensity, minimal shadowing, minimal heat production, appropriate field size, natural coloring and light fixture maneuverability have presented many challenges to surgical team members over the years. Sophisticated refinements in surgical lighting systems, along with a better understanding of lighting technology by healthcare professionals, have led the way to higher quality lighting for surgical procedures today.

Overall Purpose of the Study Guide

To define terminology that describes lighting and discuss the characteristics and preferences of lighting required during a surgical procedure.

Objectives

Upon completion of this study guide program, the participant should be able to:

1. Review fundamentals of surgical illumination.
2. Identify the main components of a surgical lighting system.
3. Review factors to consider when purchasing surgical lights.

Intended Audience

This study guide is a self-study program intended for use by perioperative nurses, surgical technologists, perianesthesia nurses and staff members, endoscopy suite nurses and staff members, acute care personnel, physician office and clinic personnel, surgeons and other healthcare professionals interested in this topic.

Introduction

Man’s earliest attempt to provide lighting for tasks began in prehistoric times with the use of fire for illumination. From burning pine knots to lighting walking paths to using a wick in a Grecian lamp, the technology of illumination progressed slowly. After many injuries and accidents with oil and gas lamps, Thomas Alva Edison developed the first practical incandescent lamp in 1879. Since then, lighting technology using artificial light sources has steadily improved.

As the art and science of surgery developed, the need for adequate illumination became obvious. Early surgery rooms were built with huge skylights and white tile walls to create an intense reflection of natural daylight. The continual variability of sunlight during different times of the day and different times of the year made this approach problematic. Artificial surgical lighting was first introduced in 1913 when clusters of incandescent lamps were suspended over the surgical patient to provide focused lighting of the operative site. Surgical lighting technology has progressed a long way from there, but the fundamental objective of illuminating the surgical site so that surgeons can adequately see what they are doing is still the driving force behind surgical lighting systems.



Surgical light circa 1934

Many surgical procedures involve operating in ever smaller spaces with ever smaller instruments. While such “minimally invasive” techniques provide a great advantage for the patient, they provide a particular challenge for the surgical team to clearly see what they are doing. Obviously, the complex surgical procedures of today require much higher levels of illumination than general room light can provide. The variety of surgical procedures also requires flexibility in the positioning and control of the lighting system.

Over the years, manufacturers of surgical lights have listened to the needs of surgeons and surgical team members and have introduced lighting products that provide:

- > Adequate illumination of the surgical site, including deep cavities
- > Minimal heating of the surgical site
- > Helpful color that renders tissue in a familiar way
- > An appropriate source of light that doesn’t need to be frequently adjusted
- > Convenient positioning of the lighthouse and aiming of the beam
- > Convenient control of lighting system features
- > Long term reliability with minimal maintenance requirements

Fundamentals of surgical illumination

To appreciate the craftsmanship and complexity of surgical lights and to use them effectively, surgical team members need to understand some basic lighting concepts as well as the definitions of specific terms used to describe surgical lights. These will be presented in the context of the primary features of surgical lighting.

Adequate illumination

The primary task of a surgical light is to provide adequate illumination of the surgical field. In order to understand how a surgical light

accomplishes this, it is necessary to be familiar with the basics of light and how it is measured.

Light

Radiation is the general name given to energy that travels through space as an electromagnetic wave. The electromagnetic spectrum includes such well-known types of radiation as microwaves, radio waves, X-rays and visible light. Light is electromagnetic radiation that is capable of stimulating the human retina and producing a visual sensation. Radiation may be characterized by its wavelength (or frequency). The table below shows the names for radiation associated with various wavelength ranges.

Type of Radiation	Wavelength Range
Ultraviolet	100 nm – 380 nm
Visible	380 nm – 770 nm
Infrared	770 nm – 1 mm

nm = nanometer, unit of length equal to 1 billionth (10^{-9}) of a meter
 mm = millimeter, unit of length equal to 1 thousandth (10^{-3}) of a meter

Illuminance

Illumination is the general term for providing light for seeing and **illuminance** is one common term for quantifying how much light is available. Specifically, illuminance is the amount of visible light that strikes a surface divided by the area of that surface. The amount of light is measured in lumens and the surface area may be measured in either square meters or square feet. Therefore, common units for illuminance are **lux**, which is one lumen per square meter, or **footcandles**, which is one lumen per square foot. (Based on the conversion factor between feet and meters, **1 footcandle = 10.76 lux.**)

Like many of our sensory organs, the human eye is able to respond over a very wide range of levels. The table below shows typical illuminance values for many common lighting conditions. Note that surgical lighting produces illuminance values that may be more intense than the noonday sun and more than 100 times brighter than the general operating room lighting.

Lighting condition	Typical illuminance
Threshold of seeing	< 1 lux (< 0.1 footcandles)
Living room	100 lux (9 footcandles)
Professional office	500 lux (46 footcandles)
Exam room (emergency department)	1,000 lux (90 footcandles)
Operating room – general lighting	1,500 lux (140 footcandles)
Noonday sun	100,000 lux (9,300 footcandles)
Surgical task lighting	150,000 lux (14,000 footcandles)

General room illumination

The overhead lighting system in an operating room should be designed to provide a relatively uniform and high level of illumination throughout the room. Approximately 1000-2000 lux (100-200 footcandles) is recommended to provide adequate lighting for performing typical activities outside the immediate operating field.¹ This amount of general illumination will provide a comfortable surrounding brightness to minimize contrast with the highly lit operative area. A surgeon’s eyes may tire if he or she persistently glances from the bright area of the surgical field to a poorly lit general area. This eye strain may result in poor visualization of the surgical field through no fault of the surgical light.

The apparent color and color rendering capability of the overhead lights should be similar to that provided by the surgical task lighting to provide the best visual environment for the surgical team. This is accomplished by matching (as closely as possible) the color temperature and color rendering index (CRI) of the two types of lighting.² (The concepts of color temperature and CRI will be discussed in detail later.) In particular, if fluorescent lights are used for general room illumination “deluxe” fluorescent lamps with a neutral white color should be specified, as these lamps give better color rendition and more closely match the color of the surgical lights than ordinary “cool white” or “warm white” fluorescent lamps.



With LED lighting, distracting shadows created by the surgeon's head are virtually eliminated from the surgical field.

Surgical site illumination

The surgical site requires much higher illumination than what is provided by general room lighting. In fact, the illuminance delivered to the surgical site by a modern surgical luminaire is among the highest provided by any artificial lighting system and can even exceed that of the noonday sun. These extremely high illuminance levels are needed because there are often partial obstructions of the beam due to the heads and shoulders of surgical team members that can significantly reduce the illuminance reaching the surgical site.

Furthermore, delivering light to the bottom of long, narrow cavities, as is commonly needed in surgery, involves multiple reflections from the side walls of the cavities, which requires high illuminance at the surface to compensate for the light that is absorbed.

The widely recognized international standard for surgical lighting specifies that a single surgical luminaire should produce between 40,000 and 160,000 lux.³ Most operating rooms provide at least two, and sometimes three or four, surgical lights. When the beams from multiple lightheads are overlapped, the illuminance will increase proportionally. Multiple luminaires lights can be used to provide additional light and may also affect the shape of the pattern and reduce the appearance of sharp shadows. Most surgical lights provide a means for adjusting the light output to suit the particular needs of the surgical team at the time.

Minimal heat

There are many sources of heat in the operating room, including equipment and people in the room. Although the operating room generally stays quite cool and comfortable, there is one particular source of heat, namely the heat carried in the beam of the surgical light, that deserves special attention because it is very concentrated and may create localized heating at the surgical site.

Radiant energy

The same radiation that produces a visible sensation when it strikes

our retina produces heat when it is absorbed by our body. However, radiation in wavelengths that are not visible may also produce heat. In fact, infrared radiation is not visible but is readily absorbed by the body and therefore may be a significant contributor to the overall amount of heat in the beam from a surgical light.

The amount of **radiant energy** reaching the surgical site depends on the amount of radiant energy emitted by the light source, how the optical components of the surgical luminaire collect and focus the light on the surgical site, and the degree to which non-visible wavelengths, such as infrared radiation, are filtered out of the beam. Well-designed surgical lights will minimize the emission of radiant energy in the infrared region so that the remaining energy is mostly in the visible region.

Irradiance

Irradiance is the amount of radiant power that strikes a surface divided by the area of that surface. Radiant power, which is simply the rate at which radiant energy is delivered, is measured in watts or microwatts and the surface area may be measured in square meters or square centimeters. Therefore, irradiance is commonly reported in watts per square meter or microwatts per square centimeter. Illuminance and irradiance are similar quantities in that both are measures of power per area. The main difference is that illuminance takes into account the sensitivity of the human eye to the radiant power, whereas irradiance does not.

Radiant heating

The most obvious effect of radiant energy is to raise the temperature of the surface that it strikes. However, there are many factors in addition to the amount of radiant energy reaching the surface that control how quickly and how high a person's tissue temperature will rise.

A person's ability to withstand a certain level of radiant energy depends on intrinsic factors, such as their age, skin pigmentation, overall health of their skin and circulatory system, as well as the effects of any medication they may have taken recently, these are known as *intrinsic factors*. There are also other factors outside of the patient, known as *extrinsic factors*, that determine how a specific heat load will raise the patient's tissue temperature. For instance, irrigating the surgical site can dramatically reduce the risk of tissue damage from excess heat, while increasing the length of exposure to the intense light can increase the risk.

For neurosurgery and for surgery on hyperemic (excessively swollen) thin tissues such as distended intestines, heat can be dangerous and produce drying or ulceration of the exposed tissues. Pediatric patients and those with compromised circulation may also be at increased risk. To reduce the risk of thermal damage to a patient during surgery due to the surgical lights, the international standard for surgical lighting limits the irradiance from a single luminaire to no more than 1000 W/m².⁴ Many modern surgical lights produce only about half of that amount, even on their highest intensity setting and smallest pattern size, which is their highest irradiance condition. However, when the beam patterns of two or more lights are overlapped, the surgical staff must consider the increased risk of overheating the exposed tissue and may need to limit the intensity of the light, limit the exposure time, or take other means to reduce the risk to the patient.

While patient safety is of utmost importance, radiant heating from the surgical lights can also play a role in the comfort of the surgical team. At times, the beam of light from the surgical lights may strike the heads and shoulders of the surgical staff during the procedure. Over time, this may cause the staff to feel some warmth due to the lights. A surgical light that produces a minimal amount of infrared radiation will be appreciated by the staff, as well as minimize the risk of harm to the patient.

Helpful color

The ability to perceive tissue, organ and skin color accurately is extremely important in surgery. Many decisions made by the surgeon are influenced by his or her ability to discriminate between subtle shades of color and mentally compare the color of a current observation with that from previous experience and training. The apparent color of an object depends on both the color of the light striking the object and reflective properties of the object. Well-designed surgical lights must provide adequate power throughout the visible spectrum so that colors are rendered in a consistent and familiar way.

Color

The apparent color of light depends on how the radiated power is distributed across the visible spectrum. The human eye has three separate types of receptors that are sensitive primarily to red, green or blue light. When the light reaching our eye preferentially stimulates one or two of these receptors, we perceive colored light. When all three of these color receptors are stimulated in approximately equal amounts, we call this sensation white light.

Color temperature

While the relative amount of light at each wavelength in the visible region of the spectrum fully describes the apparent color of the light, it is desirable to have a single number that correlates to the color. Color temperature, or more precisely, correlated color temperature (sometimes known as CCT), is a term that has been used to serve this purpose. Despite its name, color temperature is not used to describe deeply saturated colors, like reds, blues and greens, but rather to describe various shades of white. Color temperature is measured in degrees Kelvin.

Light with a color temperature in the range of 2700 – 3400K appears white but with a relatively red/yellow hue and is often referred to as “warm white.” This is typical of an unfiltered incandescent lamp. Light with a higher color temperature in the range of 4100 – 6300K appears white with a blue hue and is often referred to as “cool white.” Surgical lights typically have a color temperature around 4400K that many find to be a pure, neutral white light that is neither too yellow nor too blue.

Color Rendering Index (CRI)

With the emergence of the fluorescent lamp in the 1940’s, many consumers realized that colors did not look as good under this new light source as they did under the incandescent lamps to which they were accustomed. The color rendering index (CRI) was developed shortly thereafter to help users have an indication of how well a light source renders colors relative to a reference light source. This measure of color rendering is based on a set of 14 samples representing a wide range of colors.



Figure 3. Color Rendering Indices: CRI is the average of the first eight pastel color rendering indices. The special color rendering index for the 9th color sample, R_9 , is not included in the average, but is very important to surgeons because it represents the ability of a light source to render deep, saturated red.

A special color rendering index is calculated for each of the 14 samples, with a value of 100 indicating that the color of a sample looks the same under the light source being measured as it does under the reference light source. What is generally referred to as the color rendering index is actually the average of the specific color rendering indices for the first eight color samples.⁶

Variations in CRI of less than five points are generally imperceptible and are not considered significant. High CRI is accomplished by a light source that provides a distribution of light across the entire visible spectrum, similar to daylight, and thus colors appear realistic. A surgical light with a CRI of 92 or more is considered to have excellent color rendering ability.

Appropriate distribution of light

The optical design of the surgical lighthouse determines how the light is distributed throughout the beam, both vertically (in the direction that the beam is going) and horizontally (perpendicular to the beam direction). This determines such particular features as the pattern size and shape, uniformity of light across the pattern, focal length, depth of field and shadow control. When these features have been well-designed, the user will feel that the light performs well without precise aiming and positioning. When poorly designed, the performance of the surgical light might seem very sensitive, or worse yet, not adequate for the task.

Pattern size and shape

Most surgical lights provide some means of adjusting the pattern size – for example, by turning a central handle. **Pattern sizes** may often be adjusted from a minimum diameter of 6 inches to a maximum diameter of 12 inches. The pattern size is defined as the diameter at which the illuminance has dropped to 10% of the maximum value that occurs in the center of its beam.⁷ It is generally preferable to match the size of the beam to the size of the incision or area of interest. If the pattern is larger than the surgical site, some light will reflect from the skin or surgical drape surrounding the incision and may be uncomfortably bright and distracting to the surgeon. The shape of the beam from a single luminaire is typically circular, however, a slightly oval pattern can be created by partially overlapping the beams from multiple luminaires.

Uniformity

A well-designed surgical light will have a gradual variation in illuminance from the center to the edge of the beam. It is normal for the center of the beam to have the highest illuminance, but there should not be noticeable local “hot spots” (small areas of high brightness). If the illuminance near the edge of the beam is much lower than the center, the surgeon may feel that he needs to re-aim the luminaire more frequently in order to adequately see the entire surgical site.

Focal length and working range

The beam size and central illuminance created by a surgical luminaire will vary with the distance from the luminaire. There is a distance, called the focal length or the intended working distance, where the pattern reaches its smallest size and highest illuminance. The **focal length** of most surgical luminaires is about 1 meter (39 inches) from the face of the luminaire.

Placing the luminaire at this distance from the surgical site will provide the best performance. As the distance between the luminaire and the surgical site either increases or decreases from this intended working distance, the pattern size will increase and the illuminance will decrease. At extreme distances, the pattern may be too large and too dim to be useful and a dark spot may even develop in the middle of the beam. The working range is the range of distances from the luminaire to the surgical site for which the size and illuminance of the beam is considered acceptable. It is not a precisely defined term and is usually not included in the product specifications.

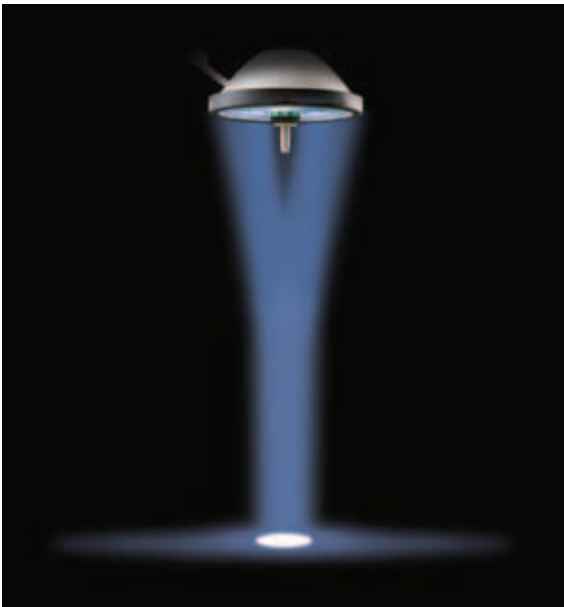

Some surgical lights allow the user to adjust the focal length. This feature can increase the working range but requires more attention by the user to make sure the lights are appropriately adjusted. A luminaire that has been designed to provide a fixed focal length and a large depth of field may be called “pre-focused.”

Depth of field

The **depth of field** is related to the general concept of working range, and is precisely defined by the IEC (International Electrotechnical Commission) standard on surgical lighting as the distance over which the illuminance in the center of the beam exceeds a certain percentage of the illuminance at the intended working distance. Prior to 2009, the specified percentage was 20%, but this value has been increased to 60% in the latest revision of the IEC standard.⁸ The larger the depth of field, the less sensitive the luminaire is to precise positioning from the surgical site. A large depth of field also helps maintain good lighting performance as the surgical procedure moves from an incision on the surface of the patient to the bottom of a deep cavity and prevents the surgeon from feeling the need to reposition the luminaire.

To help clarify these related terms, consider a typical surgical luminaire with the following characteristics:

Intended working distance (focal length)	39" (100% illuminance here)
Desirable working range	30" - 50"
Close distance where illuminance is 20%	24"
Far distance where illuminance is 20%	60"
Depth of field	36" (distance from 24" to 60")

Shadow control

Shadows are areas of relatively lower illuminance in the beam and are caused by obstructions between the light source and the surgical site. There are two distinct types of obstructions - those within the luminaire due to its construction and those between the luminaire and the surgical site often due to the heads and shoulders of surgical team members. A well-designed surgical light will eliminate all shadows due to obstructions within the luminaire. While shadows caused by the surgical team cannot be totally eliminated, they can be minimized by the design of the luminaire and the way in which it is used. Sharp shadows can be minimized by directing light to the surgical site from multiple directions and multiple locations. One of the most common ways to

minimize shadows is to use two luminaires aimed at the surgical site from different directions. The larger the diameter of the luminaire, the less likely that an obstruction will cast a sharp shadow, so most manufacturers offer luminaires with diameters greater than 20 inches. Furthermore, well-designed luminaires emit light uniformly across the front surface to further minimize the appearance of sharp shadows. The entire circular shape of the beam should be created by many small portions of the luminaire, so that small obstructions will not distort the circular pattern of the beam, but rather decrease the illuminance uniformly across the beam.

Convenient positioning

In a general purpose operating room, the location of the surgical site within the room may vary significantly based on the room set-up and the procedure being performed. It is important that the lights have the ability to be conveniently positioned for the variety of procedures that may be performed in the room. The ability to position surgical lights where they are most useful for the particular surgical procedure depends on both the reach of the suspension system and the number and location of the hubs within the operating room.

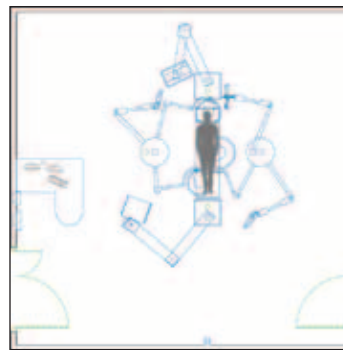

Typical ceiling-mounted suspension

A typical ceiling-mounted suspension system can position a luminaire within a ten-foot diameter cylinder that extends from the ceiling to as low as four feet above the floor. Although a simple hub can be used to mount a single luminaire, a typical system holds two luminaires and a flat panel monitor. Some large suspension systems use an auxiliary spindle to mount three or four luminaires and one or two monitors from the same hub.

One common configuration is a single suspension system centrally mounted in the room. Many hospitals have found that an alternative design using two hubs (often called a “split mount”) provides greater positioning options. The two hubs can either be positioned one on each side of the operating table, or one above the head and one above the foot of the table. The mounting location for an equipment management system (or equipment “boom”) on the ceiling should also be considered when planning the layout of equipment in the operating room.

The correct positioning of the surgical lights is important in minimizing the appearance of shadows in the beam. Using two luminaires, one positioned over the patient’s head and one positioned over the foot often provides ideal lighting, especially for abdominal incisions. The lights should be positioned high enough that surgical team members can walk around the operating table without risk of hitting their head, yet not much further than 1 meter away from the surgical site so that the light beam will maintain its maximum illuminance and minimal pattern size.

In addition to providing adequate reach, it is essential that the luminaires must not move on their own (drift) after being positioned. Drift may be caused by a poor installation. Sometimes, the tendency of the luminaires to drift can be minimized by adjusting the brakes on the suspension system, although this is not the best long-term solution since it also increases the force required to intentionally re-position the luminaire. When luminaires drift, a service call from a qualified professional is recommended in order to accurately diagnose and correct the root cause of the problem.

Aiming a surgical light to direct the beam to the surgical site may be

performed manually by either the surgeon (using sterile technique) or the circulating nurse (from outside the sterile area). A sterilizable, removable lighthandle is connected to the center post of the luminaire using sterile technique. Sterile, disposable lighthandle covers that fit on the light handle are also available for light positioning using sterile technique. Surgical lights are usually designed with non-sterile handles or ledges on the outer rim of the luminaire that permit easy maneuverability by the circulating nurse.

Convenient control

Because of the unique challenges of working in the operating room, it is critical that the basic functions of the surgical light, such as on/off, intensity adjustment, and pattern size adjustment, be easily controlled by the surgical team. Most functions, with the exception of pattern size adjustment and aiming of the beam, can be controlled from the wall-mounted control. A well laid-out control panel with graphical symbols (icons) for the various functions helps provide intuitive operation.

For the convenience of the surgeon, some basic controls such as on/off and intensity adjustment are redundantly located on the luminaire itself, often right around the central handle. The pattern size is typically adjusted by rotating the central handle.

Reliability with minimal maintenance

A well-designed surgical lighting system is a sophisticated medical device that will provide excellent performance for many years with minimal maintenance requirements. However, some degree of attention is necessary to ensure that the product continues to provide peak performance over time and does not contribute to the risk of spreading infection in the operating room.

Halogen lamp replacement



Older surgical lights contain halogen lamps that need to be replaced periodically – typically every 3-6 months. Major surgical lights provide some means of continuing to provide light output from a backup light source after the primary lamp has failed. This is done by the lighthouse detecting the failure of the primary lamp and automatically switching power to a backup lamp that has

already been installed in the luminaire. The backup lamp may be either (a) stationary and positioned as close to the primary lamp as possible, or (b) mounted on a mechanism that quickly moves into the correct optical position and moves the burnt-out lamp out of the way. In the case of the stationary backup lamp, the optical performance is slightly compromised as illuminance is decreased and the size and shape of the beam may be somewhat distorted.

The movable backup lamp typically maintains full optical performance. In either case, the changeover is very reliable and happens so quickly that there is no risk to the patient. Due to the presence of a backup lamp, it is usually not necessary to replace lamps until they burn out. However, it is critical to replace a burned out lamp as quickly as possible, either during the case if possible, or before the next case starts, in order to ensure that backup lighting is always available. Some manufacturers recommend that the both the primary and backup lamp be replaced at the same time, so that the backup lamp will always be fresh, in which case always follow the manufacturer's recommendation.

A well-designed surgical lighting system will provide a visual indication to the surgical team when either the primary or backup lamp

needs to be replaced and should ideally indicate which lamp needs to be replaced. This may be a small indicator light on the lighthouse and/or a symbol or text on the wall control.

The manufacturer's written instructions should be followed when replacing a lamp. The lighthouse should be allowed to cool before attempting to replace the burned out lamp, since portions of the lighthouse and the lamp itself can remain hot for many minutes after the light has been turned off. The glass surface of halogen lamps should not be touched with a bare hand since fingerprints can deposit oils on the lamp that will result in deterioration and discoloration, thus shortening the lamp life and reducing the lamp output. A clean cloth or glove should be used to handle lamps. It is best to grasp the lamp by the ceramic base, rather than the glass envelope in order to prevent unintentional glass breakage. Most halogen and discharge lamps are highly pressurized, even when at room temperature, so breaking the lamp's glass envelope is potentially dangerous. Safety glasses are often recommended when changing a halogen or discharge lamp.

Luminaire cleaning

Although most surgical luminaires are sealed to prevent dust from entering the lighthouse, dust, dirt and other substances can build up on outer surfaces of the luminaires, suspension system components and wall control units and may then become dislodged during the aiming and positioning of the lights. These contaminants can then be transmitted to the surgical staff or possibly become airborne and land on the patient, possibly directly in an open wound. The greatest risk of contaminating the surgical site is the accumulation of dust and debris on the luminaires and suspension arms that are positioned directly over the patient. Some installations may use tracks directly over the surgical table, which pose an additional risk of dust settling on the tracks and then falling into the surgical incision when the light is repositioned. Furthermore, dust that has amassed over time on the reflector and lens can decrease the output of the light, while dirt that has accumulated on the surgery room walls and ceilings can reduce reflectivity and can decrease the general room lighting level.

Fortunately, routine cleaning can prevent these problems. The AORN "Recommended Practices for Environmental Cleaning in the Surgical Practice Setting" addresses the care of surgical lights,⁹ as noted below:

Recommended Practice:

Patients should be provided a safe, visibly clean environment:

All horizontal surfaces within the OR (e.g., furniture, surgical lights, equipment) should be damp dusted before the first scheduled surgical procedure of the day with a clean, lint-free cloth moistened with an EPA-registered hospital disinfectant. Dust and lint are deposited on horizontal surfaces in surgical practice settings. Proper cleaning of these surfaces helps reduce airborne contaminants that may travel on dust and lint.

Sometimes, a ladder or extension pole may be needed to reach high surfaces, such as tracks mounted on the ceiling.

Surgical lighting system components

A surgical lighting system provides the artificial light that enables visualization of the operative site. The main components of the system include the **light source** that initially produces the light, the **luminaire** that contains the light source and collects and directs the light, the **suspension system** that supports the weight of the luminaire and positions and aims it where needed, the **power delivery components** that provide the electrical power and the **user interface** that allows the surgical staff to control the functioning of the system.

Light source

The **light source** converts electrical energy into visible radiation, but may also produce invisible radiation in the ultraviolet (UV) or infrared (IR) portions of the spectrum. Not only is UV and IR radiation a waste of energy since it doesn't contribute to seeing, it may also be potentially harmful to the patient.

Until very recently, the primary light source for surgical lights has been the incandescent lamp. By their very nature, these sources emit a lot of IR radiation that must be removed from the beam by the optical components (reflector, lens, filters) of the luminaire before it reaches the operative site. Halogen lamps are a variation of the basic incandescent lamp that include a special gas environment inside the lamp surrounding the filament that increases the light output and life of the lamp. Halogen lamps will burn out and need to be replaced after about 1000 hours of usage on the average (about every 6 months of typical usage), although the life of an individual lamp may vary significantly. Virtually all older surgical lights in service today use some form of incandescent lamp.

The most recent type of light source to be used in surgical lights is the LED, or light emitting diode. This revolutionary light source works on a totally different principle than the incandescent lamp and provides two significant benefits that make it particularly well-suited for use in surgical lights. First, LEDs can be designed such that they produce only visible light and not IR radiation. This eliminates the need to remove the IR, which is costly and can never be done completely. The end result is a beam of light that is cooler than that of a traditional incandescent lamp. Second, LEDs last much longer than incandescent lamps. Typically, LEDs do not burn out entirely but slowly dim as they age. They may last tens of thousands of hours (10-15 years of typical usage) before their light output is significantly reduced. The majority of the top-of-the-line surgical lights on the market today use LED light sources.

Luminaire

The **luminaire**, which may also be called the light fixture or lighthead, contains the light source and the optical components to collect and direct the light. These involve a combination of specially designed reflectors, lenses and filters. Reflectors may be made of polished metal or coated plastic. Lenses are typically made of plastic to reduce the weight of the luminaire and avoid the risk of injury due to broken glass. Sometimes special purpose coatings are used to filter out unwanted portions of the spectrum, like IR radiation, or to adjust the spectrum of the visible light to improve the desired color temperature or color rendering.

The luminaire also serves to cool the light source. The life of both incandescent and LED light sources is sensitive to the temperature at which they operate.

The luminaire provides handles or grasping surfaces to allow for ease of positioning, aiming the light and adjusting the pattern size. The handles may be removable and sterilizable or sterile covers may be placed over the handles to allow aseptic control.

Suspension system

Most major surgical lights are attached to a **suspension** system that consists of a spindle that mounts to the ceiling, a number of horizontal arms that swivel around the spindle, hinged joints (sometimes called "elbows" or "knuckles") that allow horizontal spring arms to pivot up and down, and a yoke that holds the luminaire.

Some installations use tracks to allow the lights a greater range of motion, although tracks are often challenging to keep clean. When well designed, the suspension system provides a wide range of convenient positioning possibilities, requires minimal force for positioning and prevents the lightheads from drifting after they are positioned.

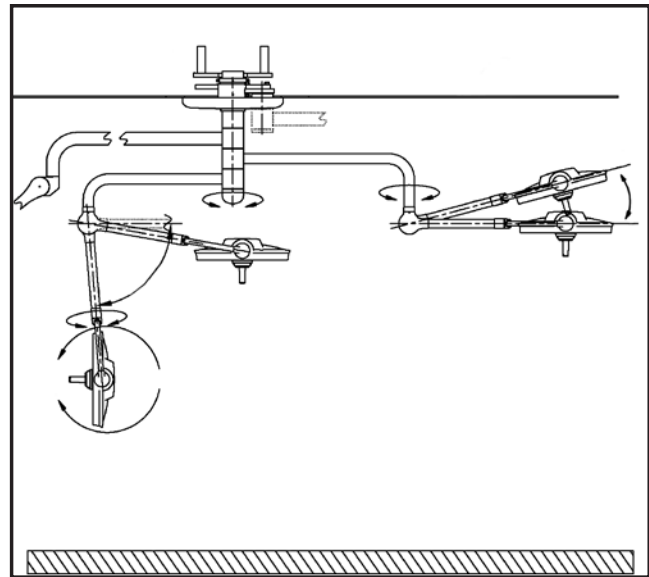

Power delivery and user interface

Surgical lights are typically provided with specially designed **power supplies** that are located in the walls or ceilings of the operating room to provide that electrical power for operating the lights. The wires that carry the electrical current from the power supplies to the lightheads run through the arms of the suspension system with special connections at the joints that allow continuous rotation of the arms without damaging the electrical wiring.

A wall-mounted **user interface** (sometimes called a wall control) that allows users to control the settings of the lights. Some basic features such as on/off and intensity adjustment may be controlled directly by the surgical staff using switches near the handle of the lighthead, as well. Sometimes, helpful information about the status of the system is displayed on the wall control. Some modern wall control units have touch switches and video displays for ease of use.

Surgical lighting regulations

There are a number of international, national and industry organizations that are concerned with the safety and effectiveness of surgical lighting. A surgical lighting system must conform to all applicable codes and regulations that govern the locality in which the lights are sold and used. Compliance to these regulations ensures that recognized product safety standards have been met. However, these regulations apply primarily to surgical lighting manufacturers. It is the responsibility of the healthcare facilities and their staff to ensure that the product has been properly installed and maintained and that the users of this equipment are properly trained in the safe use of the product. This requires that users must understand the safety implications of such practical matters as how close to the patient to place the lights and how many lights to use to illuminate a single surgical site.

U.S. Food and Drug Administration (FDA)

Among its many other responsibilities, the FDA is responsible for ensuring the safety and effectiveness of medical devices. The FDA has designated surgical lights as class II medical devices and therefore manufacturers must receive clearance from the FDA to offer them legally for sale. Since surgical lights are well-established medical products, manufacturers typically seek FDA clearance by demonstrating that their surgical light is substantially equivalent to a previously cleared product. When submitting a surgical lamp premarket notification, referred to as a 510(k), the FDA encourages manufacturers to comply with the recognized international standard for surgical lights, IEC 60601-2-41¹⁰.

International Electrotechnical Commission (IEC)

The IEC is the leading global organization that creates and maintains international standards for all electrical, electronic and related technologies. IEC 60601-1 is an international, general standard for the basic safety and essential performance of medical electrical equipment. A related standard, IEC 60601-2 - 41, contains the particular requirements for the safety of major and minor surgical lights and is the primary standard that manufacturers refer to when designing their surgical lighting products. This standard contains a detailed description of optical, electrical, mechanical and thermal quantities to measure and how to measure them. In particular, the standard establishes performance levels that must be achieved in order to comply.

Illuminating Engineering Society of North America (IESNA)

IESNA is an independent, recognized technical authority on lighting and its applications. Among its many functions, the IESNA publishes recommended practices for various lighting applications, including RP-29, a recommended practice for Lighting for Hospitals and Healthcare Facilities. This consensus opinion from a diverse committee of well-qualified lighting professionals addresses all areas of hospital and healthcare lighting, specifically including operating room lighting. Although the IESNA recommendations do not carry the weight of regulatory standards, they are still an influential expression of best practices in surgical lighting.

Purchasing surgical lights

Determining the appropriate surgical light to purchase can be a challenging exercise for healthcare professionals.

Many factors should be considered, including:

- > Performance
- > Total cost of ownership
- > Installation requirements
- > Service support
- > Facility design
- > Standardization of fixtures

The selection process may involve some or all of the following activities: reading about products, reviewing product specifications, seeing products demonstrated at tradeshow, talking with sales representatives, and trialing products in your own clinical setting.

Costs

A comprehensive analysis of the total cost of ownership will reveal that the initial cost of the surgical lighting system may not be the only significant expense. Installation costs, standard operating costs, preventive maintenance costs and possible repair costs must also be considered.

Product demonstrations

Sales professionals for surgical light manufacturers can assist with the determination of costs, benefits and features. Sales representatives may organize an appointment with surgical team members (especially surgeons) to visit other facilities to observe a specific model and brand of surgical light while it is being used. Sometimes, a surgical light can be installed in your own facility for a trial period in order to evaluate its performance.

The demonstration of a surgical light should show:

- > A bright, uniform beam with no apparent “hot spots”
- > A light pattern having at least a six inch diameter
- > The sensitivity of the pattern size and brightness to the positioning of the luminaire (This can be shown by observing the beam formed on a surface, such as a surgical table, as the

luminaire is moved closer to and then further away from the surface.)

- > A consistent white color throughout the beam
- > The no-drifting properties of the suspension system when the luminaire is placed in any position
- > Shadow reduction and beam direction (This can be observed by using a three quart can to represent a deep surgical cavity. The light should be positioned to see if it can be properly directed into the can and to see if the examiner’s head interferes with the light by producing shadows.)

When comparing surgical lights, the preferences voiced by different team members within the surgical department must be considered, since each person may have distinct needs and relative priorities for the various features provided by a surgical light.

Surgeon preferences

Purchasing surgical lights is usually surgeon-driven since optimal illumination is a requirement of a successful surgery.

Some of the features surgeons will select and expect include:

- > Bright, pre-focused or easy to focus light
- > Maximum shadow reduction
- > Consistent illumination
- > Excellent intensity ranges for brightness without glare
- > Excellent cavity illumination
- > No distortion of colors – natural color rendition
- > Adjustable patterns and illumination levels
- > Reliable performance
- > Minimal heat in the beam
- > Easy to position (360° rotation with no dead spots)
- > Low height positioning
- > Sterile control that is not easily contaminated
- > Stable, drift-free suspension

Perioperative nurse preferences

Perioperative nurses are often responsible for the care and positioning of surgical lights.

Their preferences in surgical lights usually include:

- > Easy to position
- > Non-sterile grasping surface
- > Drift-free
- > Reliable performance
- > Easy to operate intensity control (usually wall mounted in the OR)
- > Easy to clean
- > Durable aseptic design (e.g., easy to clean tracks)
- > Ease and safety when changing light bulbs, if required

Administration preferences

Administrators often focus on the costs of capital expenditures, but today quality and reliability are often considered equally important.

Some of the features preferred by administrators include:

- > Cost-effective
- > Reliable performance
- > Standardized
- > Universal applications (versatility)
- > Low maintenance costs
- > Service contracts
- > Easy and cost-effective installation
- > Domestic supplier
- > Purchase directly from the manufacturer

Light comparison checklist

When comparing the features and performance of surgical lighting systems as part of an evaluation that will lead to a purchase recommendation, a checklist may be useful to make sure decision makers are thoroughly considering all aspects.

The following set of specific questions has been organized by topic:

- > Illumination
 - How bright do you want the light?
 - Over what range and with what intervals can the light intensity be adjusted?
 - What is the peak illuminance (in lux) generated by the light?
 - Based on the anticipated procedures that will be performed in the OR, how many luminaires, and what size luminaires, are needed?
- > Color Temperature
 - What is the color temperature (in Kelvin) of the light?
- > Color Rendering
 - What is the CRI? (100 is the maximum when measuring color rendition)
 - What is the special color rendering index for the 9th color sample (R_9), which represents the ability of the light to render deep, saturated red? (100 is the maximum when measuring R_9)
- > Radiant Heat
 - What is the peak irradiance (in watts per cm^2) generated by the light?
 - What is the ratio of radiant heat to light produced by the luminaire?
- > Heat dissipation
 - What is the total power consumption (in watts) of the luminaire? This value should be as low as possible for a given peak illuminance, since most of this power needs to be removed from the luminaire to reduce surface temperatures and keep the room and its occupants comfortable.
 - What is the maximum temperature of the exposed surfaces of the luminaire, particularly the intended touching surfaces (lighthead and rim of the luminaire)?
- > Shadow Reduction
 - How noticeable are shadows when there are obstacles between the light and surgical site?
- > Depth of field
 - How far away from the surgical site should the luminaire be placed for optimal performance?
 - How sensitive is the illuminance and pattern size to the positioning of the luminaire?
 - Is it possible to adjust the focal length of the luminaire? If so, how?
- > Positioning
 - How easy is it to position and aim the luminaires?
 - How far do the suspension arms reach around the operating table?
 - Will other ceiling-mounted equipment inhibit the movement of the surgical light?
 - What positioning flexibility is needed? If low lateral positioning is required, how close to the floor (in inches) can lights be positioned and over what range of angles (in degrees) can lights be aimed?
 - What types of mounting are needed: track mount, central, or side mounts?

- > Installation
 - What construction (structural and electrical) must be done to accommodate a hub-mounted light and a wall-mounted control?
 - Will the new light be able to use any of the existing wiring and structural support?
 - What other pieces of equipment are already mounted or will be mounted in the room that may affect the installation, such as ceiling mounted microscopes, laminar air flow systems, etc.?
- > Backup bulb – halogen lamp specific considerations
 - What is the impact on illuminance, pattern size and shape, and shadow control when a bulb burns out and the replacement bulb comes on?
 - What are the maintenance costs when bulbs burn out?
 - Will you have to replace one bulb per lighthead or multiple bulbs?
 - How often will the staff be changing bulbs?
 - How are the bulbs changed?
- > Total cost of ownership
 - In addition to the initial purchase price, how much will it cost to install, operate and maintain the surgical lighting system?

Summary

Surgical lights can be a challenge or a joy to surgeons, nurses and other healthcare professionals. The common language and understanding that has been developed recently between the surgical team members and lighting engineers have led to the sophisticated advancements available in surgical lighting systems today. As operative procedures have become more complex, quality surgical lighting plays a key role in positive patient outcomes. After all, effective surgical lighting makes successful surgeries possible!

Glossary

Brightness

The attribute of the visual sensation related to the amount of light reaching the eye. In technical usage, the term brightness may be used to mean the luminance of a surface, although it is preferable to reserve the term brightness to mean the subjective sensation.

Color

The characteristic of light by which a person can distinguish a difference between two patches of light of the same shape and size. The apparent color is determined by the relative strength of different wavelengths of light. Names have been assigned for various colors of light depending on the dominant wavelength. For instance, light with a dominant wavelength in the range of 500-570 nm is considered green.

Color Rendering Index (CRI, R_a)

Measures the effect of a specific light source on the color appearance of the objects being illuminated by that source. A CRI of 100 is the highest possible value and indicates that the light source renders color in the same way as a particular reference source. Surgical lights must provide a CRI greater than 85 which ensures excellent color rendering for surgical applications.

Color temperature (Correlated color temperature, CCT)

A temperature measured in Kelvin(K) that describes the apparent color of various shades of white light. Typical surgical lights have a color temperature around 4400 K.

Depth of field

Indicates the length of the range of distances from the surgical luminaire for which the beam maintains its quality and usefulness. A large depth of field ensures that the pattern size of the beam and the amount of light are not very sensitive to the distance that the lighthouse is positioned from the surgical site. Depth of field may also be referred to as Depth of Illumination.

Discharge lamp (or gas discharge lamp)

A type of artificial light source that passes electrical current through an ionized gas, creating an electrical discharge that produces radiation that may be directly visible or converted to visible light through the use of phosphors.

Fluorescent lamp

A specific type of gas discharge lamp that produces light by using a low-pressure mercury discharge to generate ultraviolet radiation that is then transformed into visible radiation using a fluorescent coating on the wall of the lamp to shift the wavelengths.

Focal length

The distance from the surgical luminaire at which the beam of light forms the smallest spot size and has the highest illuminance. The focal length represents the intended working distance for the surgical luminaire, since positioning the luminaire at (or near) this distance from the surgical site provides the best possible illumination.

Footcandle (fc)

A unit of illuminance equal to 1 lumen / ft². One fc = 10.76 lx.

General lighting

Lighting designed to provide an adequate level of illumination throughout a large area, such as an entire room.

Halogen lamps

A variation of the basic incandescent lamp that includes a special gas environment inside the lamp surrounding the filament that increases the light output and life of the lamp.

Illumination

The general term for light on a surface that enables seeing that surface.

Illuminance

The surface density of light striking a surface, that is, the amount of light per surface area. Illuminance is typically measured in lux or footcandles. This term is not used to describe surfaces that are generating light (see luminance).

Incandescent lamp

A type of artificial light source that produces light by running an electrical current through a filament wire, causing it to get hot enough to radiate in the visible portion of the electromagnetic spectrum.

IR (Infrared)

Infrared (IR) radiation is radiant energy in the portion of the electromagnetic spectrum between 770 nm – 1 mm; it cannot be detected by the human retina and is often filtered out of the beam of light as a means of reducing the heat at the surgical site.

Irradiance

The surface density of radiant power striking a surface, that is, the amount of power per surface area. Irradiance is typically measured in watts per square meter (w/m²).

Kelvin

A unit of measure (degrees) used to describe various shades of white (color temperature).

Lamp

An artificial source of light, such as an incandescent lamp or fluorescent lamp.

LED (light emitting diode)

A type of artificial light source that produces light by passing electrical current across the junction between dissimilar solid materials. LEDs are part of a more general category of light sources called solid state lighting.

Light

Radiant energy in the portion of the electromagnetic spectrum between 380 nm and 770 nm that is detected by the human retina and produces a visual sensation. The term “light” should be restricted solely to radiation in the visible region of the spectrum, not ultraviolet (UV) or infrared (IR) radiation. The term “light” is also commonly used to refer to the lamp or luminaire that is producing the light.

Lumen (lm)

The unit of luminous flux used to measure the amount of visible radiant power. The amount of lumens produced by a light source is one common way to measure how much light is available for seeing.

Luminaire

A complete lighting unit consisting of one or more light sources (lamps), components to position and aim the light and means to connect the lamp to the power supply. Also referred to as a lighting fixture or lighthouse.

Lux (lx)

A unit of illuminance equal to 1 lumen / m². One lx = 0.0929 fc.

Nanometer (nm)

A unit of length equal to 10⁻⁹ meters, commonly used for describing the wavelength of light.

Pattern size

The diameter at which the illuminance has dropped to 10% of the maximum value that occurs in the center of its beam.

R₉

R₉ is the special color rendering index corresponding to the 9th color sample used to measure color rendering. While R₉ is not included in the general color rendering index (CRI), it is very important in surgical applications because it represents the ability of a light source to render deep, saturated reds.

Radiant Energy

The amount of heat produced by a light source due to both visible and invisible (infra-red) radiation. The amount that reaches the patient depends on both the amount of radiant energy created by the light source as well as the efficiency of the lighting system to filter out the heat.

Shadow reduction (or shadow control)

The ability of a lighting system to minimize sharp shadows in the beam due to obstructions between the light source and the surgical site, such as the heads and shoulders of members of the surgical team.

Spectrum

A range of wavelengths. The visible portion of the electromagnetic spectrum contains wavelengths between 380 nm and 770 nm.

Suspension system

Means by which surgical lights are suspended from the ceiling, typically consisting of a spindle that mounts to the ceiling, a number of horizontal arms that swivel around the spindle, hinged joints (sometimes called “elbows” or “knuckles”) that allow horizontal spring arms to pivot up and down, and a yoke that holds the luminaire.

Task lighting

Lighting designed to provide a sufficient illumination in a specific area, such as the work surface of a desk or the surgical site in an OR, to perform a particular task at that location. Task lighting provides illuminance levels that often far exceed those of general illumination.

UV (ultraviolet)

Ultraviolet (UV) radiation is radiant energy in the portion of the electromagnetic spectrum between 100 nm – 380 nm; it cannot be detected by the human retina.

Wavelength

Distance between two successive peaks on a periodic (repeating) wave. The wavelength of light is typically measured in nanometers.

Working range

The range of distances from the luminaire to the surgical site for which the size and illuminance of the beam is considered acceptable. It is not a precisely defined term and is usually not included in the product specifications.

References

- 1 Rea, MS (editor), IESNA Lighting Handbook, 9th edition, New York: Illuminating Engineering Society of North America, 2000, p. 15-22.
- 2 IESNA Health Care Facilities Committee, Recommended Practice for Lighting for Hospitals and Health Care Facilities, ANSI/IESNA RP-29-06, New York: Illuminating Engineering Society of North America, 2006, p. 17.
- 3 IEC 60601-2-41, 2nd edition, Medical electrical equipment – Part 2-41: Particular requirements for basic safety and essential performance of surgical luminaires and luminaires for diagnosis, draft, 2009, p. 21.
- 4 Ibid., p. 33.
- 5 Beck, WC; Schreckendgust, J; Geffert, J, The Color of the Surgeon's Task Light, Lighting Design and Application, IESNA, Vol. 9, No. 7, July 1979, p. 54-57.
- 6 CIE, Method of measuring and specifying colour rendering properties of light, CIE publication, No 13.3, 1995.
- 7 IEC 60601-2-41, 2nd edition, Medical electrical equipment – Part 2-41: Particular requirements for basic safety and essential performance of surgical luminaires and luminaires for diagnosis, draft, 2009, p. 11.
- 8 Ibid., p. 11.
- 9 Recommended Practices for Environmental Cleaning in the Surgical Practice Setting, 2004, Denver, CO, Association periOperating Registered Nurses (AORN), p. 273-279.
- 10 Guidance Document for Surgical Lamp 510(k)s, US Department of Health and Human Services, Food and Drug Administration, Center for Devices and Radiological Health, July 1998, p. 1.

Suggested Readings

- Beck, WC, Operating Room Lighting, 2nd edition, Erie, PA, 1987, American Sterilizer Company Fischer, AL, Medical Lighting, Biophotonics International, May 2007, p. 30 -34.

Review Questions

- The illuminance produced by a surgical light is typically how many times brighter than the general OR room lighting?
 - 2X
 - 10X
 - 25X
 - 100X
- If the surgical site is not bright enough, it is always possible to increase the brightness by moving the luminaire closer to the site.
 - True
 - False
- Which of the following does not have a significant effect on the amount of radiant heat delivered to the surgical site?
 - adjusting the color temperature of the light
 - overlapping the beams from multiple luminaires
 - decreasing the irradiance produced by a single luminaire
 - increasing the intensity of the light
- Which of the following do not have a significant effect on the apparent color of light and the ability to show the color of objects?
 - color temperature
 - irradiance
 - illuminance
 - color rendering index
- A well-designed surgical light can help minimize shadows caused by which of the following?
 - internal structures within the lighthead itself
 - heads and shoulders of members of the surgical team
 - instruments held by the surgeon close to the surgical site
 - All of the above
- What does a surgical light's "depth of field" indicate?
 - how large the pattern size is
 - how far away from the surgical site the lighthead should be placed
 - how sensitive the illuminance and pattern size are to precise positioning
 - how well the lighthead reduces shadows in the beam
- What is the primary benefit of adjusting the pattern size to match the size of the area of interest at the surgical site?
 - to save energy
 - to keep light from bouncing back into the surgeon eyes that might cause distraction or eye fatigue
 - to reduce shadows
 - to reduce the amount of heat reaching the patient
- The AORN Recommended Practices for Environmental Cleaning in the Surgical Practice Setting states that for the care of surgical lights:
 - all horizontal surfaces within the OR, such as surgical lights, should be damp dusted before the first scheduled surgical procedure of the day
 - a clean, lint-free cloth moistened with a facility-approved cleaning agent should be used
 - lights should be cleaned weekly
 - A & B
- When analyzing the expense of a surgical light, which of the following should be considered:
 - Initial purchase price
 - Maintenance and operating costs
 - Lamp replacement costs, if any
 - All of the above
- The manufacturer of a surgical lighting system must receive clearance from which organization before the light can be legally marketed for sale in the U.S.:
 - OSHA
 - IEC
 - FDA
 - IESNA
 - All of the above

- Answers to Review Questions & Section Sources:
- D (Fundamentals of Surgical Lighting – Adequate Illumination)
 - B (Fundamentals of Surgical Lighting – Appropriate Distribution of Light)
 - A (Fundamentals of Surgical Lighting – Minimal Heat)
 - B and C (Fundamentals of Surgical Lighting – Helpful Color)
 - D (Fundamentals of Surgical Lighting – Appropriate Distribution of Light)
 - C (Fundamentals of Surgical Lighting – Appropriate Distribution of Light)
 - B (Fundamentals of Surgical Lighting – Appropriate Distribution of Light)
 - D (Fundamentals of Surgical Lighting – Reliability with Minimal Maintenance)
 - D (Purchasing Surgical Lights)
 - C (Surgical Lighting Regulations)

Registration Evaluation Form

Study Guide #3: Lighting the Way to Surgery: What is Needed in a Surgical Light

Last Name

First Name/M.I.

RN/LPN/LVN License Number (Circle one: RN - LPN - LVN)

Non-RN: License or Social Security Number

Health Care Facility

Health Care Facility Street Address	City	State	ZIP Code
Current Home Street Address	City	State	ZIP Code
For International Address:	Country	Province/Postal Code	
Area Code /Telephone Number	E-Mail Address		

- Please check here if you want the certificate to be mailed to the address above.
- Please check here if you want the certificate e-mailed to you at the e-mail address above.

To receive continuing education credit, please complete the evaluation form and mail, fax or e-mail the completed form to STERIS Corporation.

Rate on a scale of: 1=low 5=high

To what extent did the study guide meet the 3 stated objectives below?

- | | | | | | |
|--|---|----------------------------|----------------------------|----------------------------|----------------------------|
| 1. Review fundamentals of surgical illumination. | <input type="checkbox"/> 1 | <input type="checkbox"/> 2 | <input type="checkbox"/> 3 | <input type="checkbox"/> 4 | <input type="checkbox"/> 5 |
| 2. Identify the main components of a surgical lighting system. | <input type="checkbox"/> 1 | <input type="checkbox"/> 2 | <input type="checkbox"/> 3 | <input type="checkbox"/> 4 | <input type="checkbox"/> 5 |
| 3. Review factors to consider when purchasing surgical lights. | <input type="checkbox"/> 1 | <input type="checkbox"/> 2 | <input type="checkbox"/> 3 | <input type="checkbox"/> 4 | <input type="checkbox"/> 5 |
| 4. To what extent is this learning method easy-to-use? | <input type="checkbox"/> 1 | <input type="checkbox"/> 2 | <input type="checkbox"/> 3 | <input type="checkbox"/> 4 | <input type="checkbox"/> 5 |
| 5. How much time was required to read the content, take the test, compare your answers and complete the evaluation form? | _____ hours _____ minutes | | | | |
| 6. Has the provider disclosed the conflict of interest or lack thereof declared by the planners and content specialist? | Yes _____ No _____ (Review inside cover page) | | | | |
| 7. Was the content presented without bias of any commercial product or drug? | Yes _____ No _____ | | | | |

I have completed all the requirements for this entire activity (please sign and date).

Your signature is required to attest that you have completed the requirements for this activity.

Please mail this completed form to:

STERIS Corporation
Education Department
5960 Heisley Road
Mentor, Ohio 44060-1834
Fax: 440-392-8902
E-mail: clinicaleducation@steris.com

